

Chapter 20.48

DENSITY AND DIMENSIONAL REGULATIONS

Sections:

- 20.48.010 Minimum Lot Size Requirements.
- 20.48.020 Residential Density.
- 20.48.030 Lot Shape and Minimum Lot Widths.
- 20.48.040 Building Setback Requirements.
- 20.48.042 Sight Visibility Areas at Intersections.
- 20.48.044 Garage Setbacks/Minimum Driveway Length
- 20.48.050 Accessory Building Setback Requirements.
- 20.48.060 Building Height Limitations.
- 20.48.064 Maximum Lot Coverage.
- 20.48.090 Density on Lots Where Portion Dedicated to City for Park and Recreational Facilities.
- 20.48.094 Density on Lots Created Through Short Subdivision Where Portion Dedicated to City for Right-of-Way.

20.48.100 Fences and Walls

20.48.110 Density and Dimensional Diagrams

20.48.120 Lot Layout Diagrams

Commented [AR1]: Added a new section to enforce the fencing requirements.

Commented [AR2]: Added two sections that illustrate the density and dimensional standards and lot layouts.

20.48.010 Minimum Lot Size Requirements.

Subject to the provisions of Section [20.48.094 \(Density on Lots Created Through Short Subdivision Where Portion Dedicated to City for Right-of-Way\)](#), Section [20.44.060 \(Minimum Parcel Sizes for Class "A," "B," or "C" Mobile Homes\)](#), Section [20.44.062 \(Mobile Home Parks\)](#), and Section [20.44.096 \(Penal and Correctional Facilities\)](#) all lots in each zone shall have at least the amount of square footage indicated in [Table 20.48-51: Density and Dimensional Standards](#).

Commented [AR3]: Delete Class "A", "B", or "C" from mobile homes. This was removed in chapter 20.44 as the state regulations make it so only certain mobile homes are allowed.

Commented [AR4]: Updated table number. There is only one table so renamed to 1 from 5.

20.48.020 Residential Density.

- (a) Subject to Subsection (b) and the provisions of Section [20.48.094 \(Density on Lots Created Through Short Subdivision Where Portion Dedicated to City for Right-of-Way\)](#), and except as provided in Section [20.44.062 \(Mobile Home Parks\)](#), every lot developed for residential purposes shall have the number of square feet per dwelling unit indicated in Table 20.48-5: Density and Dimensional Standards. In determining the number of dwelling units permissible on a tract of land, fractions shall be rounded down to the nearest whole number.
- (b) ~~Except in the High Density Residential District, duplexes~~ ~~Duplexes~~ and two-family conversions shall be allowed only on lots having at least one hundred fifty percent of the minimum square footage required for one dwelling unit on a lot ~~within such the Residential Ultra Low Capacity and Residential Low Capacity districts.~~

Commented [AR5]: Duplexes are allowed outright in all residential zones. Duplexes in the two lowest residential capacities are still required to have 1.5 the lot size.

20.48.030 Lot Shape and Minimum Lot Widths.

- (a) No lot may be created that is so narrow or otherwise so irregularly shaped that it would be impracticable to construct on it a building that:
- (1) Could be used for purposes that are permissible in that zoning district, and
 - (2) Could satisfy any applicable setback requirements for that district, ~~and~~
 - (2)(3) ~~Shall not be a panhandle or flag lot.~~

Commented [AR6]: Added the restriction of panhandle or flag lots. These lots cause access issues and allow private roads/driveways when public road standards should be used.

- (b) Without limiting the generality of the foregoing standard, and except as provided by subsection (d), indicates minimum lot widths that are recommended and are deemed presumptively to satisfy the standard set forth in Subsection (a).
- (c) Lot width shall be determined by the diameter of the largest circle that can be drawn within the boundaries of a lot. The diameter of the circle must be equal to or greater than the minimum lot width of the underlying zone.
- (d) On the bulb of cul-de-sacs, the minimum lot frontage along the right-of-way line shall be twenty feet and forty feet at the building setback line.
- (e) Shared driveways shall be permitted only on the bulb of a cul-de-sac, but are allowed in other settings as approved by the Director. Shared driveways shall be a minimum of twenty-four feet in width.
- (f) No lot created after the effective date of this title that is less than the recommended width shall be entitled to a variance from any building setback requirement.

20.48.040 Building Setback Requirements.

- (a) Subject to Section [20.48.050 \(Accessory Building Setback Requirements\)](#) and the other provisions of this section, no portion of any building or any freestanding sign may be located on any lot closer to any lot line than is authorized in Table 20.48-51: Density and Dimensional Standards.
 - (1) As used in this section, the term “lot boundary line” refers to lot boundaries other than those that abut streets. For the purpose of measuring setbacks, alleys shall not be considered a public street. Setbacks from alleys shall be the same as from a lot boundary line.
 - (2) As used in this section, the term “building” includes any substantial structure, which by nature of its size, scale, dimensions, bulk, or use tends to constitute a visual obstruction or generate activity similar to that usually associated with a building. Without limiting the generality of the foregoing, the following structures shall be deemed to fall within this description:
 - (A) Gas pumps and overhead canopies or roofs.
 - (B) Fences and hedges running along lot boundaries adjacent to public street rights-of-way if such fences and hedges exceed forty-two inches ~~(unless located in the sight visibility area, then thirty inches maximum)~~, except that the setback for fences or hedges up to ~~six~~ seven feet high shall be ten feet from the ultimate right-of-way along exterior side yard lot boundaries adjacent to public streets provided that the area between the right-of-way and fence are well landscaped and maintained by the property owner. Subject to Section 20.48.100 and Chapter 20.46 (Design). Also see Figure 2 and 3.
 - (3) Notwithstanding any other provision of this title, a sign may be erected on or affixed to a structure that (i) has a principal function that is something other than the support of the sign (e.g., a fence), but (ii) does not constitute a building as defined in this title, only if such sign is located so as to comply with the setback requirement applicable to freestanding signs in the district where such sign is located.
- (b) Whenever a lot in a nonresidential district has a common boundary line with a lot in a residential district lying in the ~~R-MDRMC~~, ~~R-Mod~~, ~~R-LMDRLC~~, or ~~SR-RULC~~ zone, then the setback for the non-residential property along that common boundary shall be thirty feet.
- (c) Setback distances shall be measured from the property line to a point on the lot that is directly below the nearest extension of any part of the building that is substantially a part of the building itself, except eaves, including but not limited to chimneys, and not a mere appendage to it (such as a flagpole, etc.).

Commented [AR7]: Provided additional information

Commented [AR8]: The International Building Code moved from 6 feet to 7 feet for fences requiring a permit. The land use code has been updated to reflect the IBC, except 6 feet of solid fence is allowed with 1 foot of lattice or other decorative materials.

Commented [AR9]: Provided additional sections where fences requirements are located and the new illustrations.

Commented [AR10]: Updated zoning designations.

- (d) Whenever a private road that serves more than four lots, more than four dwelling units, or that serves any nonresidential use tending to generate traffic equivalent to more than four dwelling units is located along a lot boundary, then buildings and freestanding signs shall be set back from the private road just as if such road were a public street.
- (e) In any residential district, front porches may extend into the setback from the street right-of-way line up to fifty percent of that setback.
- (f) All buildings shall be set back a minimum of fifteen feet from any open drainage facility.
- (g) All buildings shall have a minimum setback of five feet from any easement.
- (h) Marijuana producing and processing operations on lots abutting residentially zoned lots shall be set back a minimum of thirty feet for indoor operations and fifty feet for outdoor operations.

20.48.042 Sight Visibility Areas at Intersections.

At the intersection of two streets, either public or private, no structure, sign, vegetation, or anything else that obscures sight shall exceed thirty inches in height in the area described by a triangle having two twenty-five-foot legs along the curb faces of the streets from the streets' point of intersection, and a diagonal line connecting the ends of these lines.

20.48.044 Garage Setbacks/Minimum Driveway Length

- (a) All residential driveways taking access from a public road (not including alleys) shall be a minimum of twenty-two feet in length from the right-of-way ~~and be setback from the face of the primary structure a minimum of eight feet. Permeable materials should be used on private driveways when feasible. Driveways shall be impervious surface (concrete and asphalt) and utilize LID drainage when feasible.~~
- (b) All residential driveway taking access from a public alley or private drive shall be either five feet in length or a minimum of twenty feet in length from the property line.
 - (1) If a five-foot driveway length is used and the garage is attached, then the garage shall be recessed from the face of the primary structure a minimum of five feet
 - (2) If a minimum twenty-foot driveway is used, then the garage shall be setback from the face of the primary structure a minimum of eight feet.

Commented [AR11]: Added requirements for recessed garages for new residential structures. This is for street aesthetics so the garage does not dominate the street corridor.

Added impervious surface for all driveways and the use of LID drainage.

20.48.050 Accessory Building Setback Requirements.

All accessory buildings in residential districts (i.e., those established by Section [20.36.010 \(Residential Districts Established\)](#) must comply with the ultimate street right-of-way and side lot boundary setbacks set forth in Section [20.48.040 \(Building Setback Requirements\)](#).

20.48.055 Building Setbacks for Multi-Family Units.

There shall be a minimum separation between every ten attached units or every three hundred feet.

20.48.060 Building Height Limitations.

- (a) For purposes of this section:
 - (1) The height of a building shall be the vertical distance measured from the mean elevation of the finished grade of the perimeter of the building to the highest point of the building.
 - (2) A point of access to a roof shall be the top of any parapet wall or the lowest point of a roof's surface, whichever is greater. Roofs with slopes greater than seventy-five percent are regarded as walls.
- (b) Subject to the remaining provisions of this section, building height limitations in the various zoning districts shall be as listed in Table 20.48-~~51~~: Density and Dimensional Standards.

- (c) Subject to Subsection (d), the following features are exempt from the district height limitations set forth in Subsection (b):
- (1) Chimneys, church spires, elevator shafts, and similar structural appendages not intended as places of occupancy or storage,
 - (2) Flagpoles and similar devices,
 - (3) Heating and air conditioning equipment, solar collectors, and similar equipment, fixtures, and devices.
 - (4) Certain wireless communications facilities, as provided in Section [20.44.034 \(Wireless Communications Facilities\)](#).
- (d) The features listed in Subsection ~~(c)~~ are exempt from the height limitations set forth in Subsection (b) if they conform to the following requirements:
- (1) Such features may consume not more than one-third of the total roof area.
 - (2) The features described in Subsection ~~(c)~~ (3) above must be set back from the edge of the roof a minimum distance of one foot for every foot by which such features extend above the roof surface of the principal building to which they are attached.
 - (3) The permit-issuing authority may authorize or require that parapet walls be constructed (up to a height not exceeding that of the features screened) to shield the features listed in Subsections ~~(c)~~ (1) and (3) from view.
- (e) Notwithstanding Subsection (b), in any zoning district the vertical distance from the ground to a point of access to a roof surface of any nonresidential building or any multi-family residential building containing four or more dwelling units may not exceed thirty-five feet unless the fire chief certifies to the permit-issuing authority that such building is designed to provide adequate access for fire fighting personnel or the building inspector certifies that the building is otherwise designed or equipped to provide adequate protection against the dangers of fire.
- (f) Towers, monopoles, and antennas are allowed in all zoning districts to the extent authorized in Section [20.40.019 \(Table of Permissible Uses\)](#), ~~use classification 18.000.~~

Commented [AR12]: Updated code section and removed classification that is no longer in use.

20.48.064 Maximum Lot Coverage.

- (a) The maximum allowable lot coverage with structures shall be as listed in Table 20.48-~~51~~: Density and Dimensional Standards.
- (b) In all residential districts, no more than forty percent of the area within the setback from a street right-of-way may be an impervious surface, except, that anyone may install a driveway, up to double-wide, regardless of the coverage achieved.

20.48.090 Density on Lots Where Portion Dedicated to City for Park and Recreational Facilities.

- (a) Subject to the other provisions of this section, if (i) any portion of a tract lies within an area designated on any officially adopted city plan as part of a proposed public park, greenway, or independent bikeway (i.e., not a part of a street), and (ii) before the tract is developed, the owner of the tract, with the concurrence of the city, dedicates to the city that portion of the tract so designated, then, when the remainder of the tract is developed for residential purposes, the permissible density at which the remainder may be developed shall be calculated in accordance with the provisions of this section.
- (b) If the proposed use of the remainder is a two-family or multi-family project, then the permissible density at which the remainder may be developed shall be calculated by regarding the dedicated portion of the original lot as if it were still part of the lot proposed for development.
- (c) If the portion of the tract that remains after dedication as provided in Subsection (a) is divided in such a way that the resultant parcels are intended for future subdivision or development,

then each of the resultant parcels shall be entitled to its *pro rata* share of the “density bonus” provided for in Subsections (b) and (c).

20.48.094 Density on Lots Created Through Short Subdivision Where Portion Dedicated to City for Right-of-Way.

Where land is dedicated to the public for widening existing rights-of-way, the minimum parcel size for lots created through the short subdivision process *only* may be reduced by an equivalent square footage as that dedicated, not to exceed ten percent of the required minimum parcel size.

20.48.100 Fence and Wall Height Requirements

Commented [AR13]: Added an additional section for fences.

(a) Fence Height.

- (1) Front yard fences abutting a sidewalk may be a maximum of 42” (3.5 feet) in height when within 10 of the right-of-way and installed outside of the ultimate right-of-way and sight visibility areas.
- (2) If the front yard fence is located in the sight visibility area, then a maximum of 30” is allowed within the triangle area. The fence may resume allowed heights once clear from this area.
- (3) Side and Rear yard fences may be built on the property line to a height of up to 7 feet (except corner lots need to abide by section (1) above). The fence may consist of up to 6 feet opaque, with 1 foot of lattice or other decorative design.
- (4) Architectural fence requirements and materials are located in Chapter 20.46 Design and within the Development Design Standards.

(b) Wall Height.

- (1) Walls may be installed for retaining soils, screening parking areas, or in place of a fence.
- (2) Walls are required to be decorative and shall follow the requirements of Chapter 20.46 Design and within the Development Design Standards.
- (3) Walls over 4 feet in height require a building permit and shall be structurally engineered.

Table 20.48-51: Density and Dimensional Standards⁴

Zone	Minimum Lot Size Standard Subdivision (square feet)	Minimum Residential Densities (Minimum Square Feet per Dwelling Unit)	Minimum Lot Width (ft.)	Building Setback Requirements—Minimum Distance, in feet, from:							Height Limitation (ft.)	Max. Lot Coverage (%)
				Non-Arterial Street Right-of-Way ¹ Line		Arterial Street Right-of-Way ¹ Line		Rear Lot Boundary Line ²	Side Lot Boundary Line or Alley	ECA Buffer		
				Building	Freestanding Sign	Building	Freestanding Sign	Building	Building and Freestanding Sign			
Suburban Residential Residential Ultra Low Capacity	9,600 or Larger³	9,600 1-4 Du/Ac	70	25	10	40	10	Primary – 20 Accessory - 5	5	15	35	35
Residential Low/Moderate Density Residential Low Capacity	7,200 – 9,600	7,200 5-6 Du/Ac	60 50	20	10	40	10	Primary – 20 Accessory - 5	5	15	35	35
Residential Moderate Density Capacity	7,200 4,000 – 6,200	7,200 7-11 Du/Ac	60 30	20	10	40	10	Primary – 20 Accessory - 5	5	15	35 45	35
Residential Medium Capacity	2,800 – 3,600	12-16 Du/Ac	30					Primary – 20 Accessory - 5	5		45	35
Residential High Density Capacity	4,300	0 ² 17+ Du/Ac	45 30	20	5	20	10	Primary – 20 Accessory - 5	5	15	45	75
Old Town Residential	4,300	4,300	45	20	10	40	40	5	5	15	35	35
Old Town Residential	All Density and Dimensional Standards are Regulated by the Old Town Residential Design Standards ⁴											
Neighborhood Commercial	6,000	0 ² 0 ⁵	50	0 ⁴ 0 ⁵	10	20	10	Primary – 20 Accessory - 5	5	15	45	100
Old Town Business 1 ⁵	0 ³ 0 ⁷	0 ² 0 ⁵	60	0 ⁴ 0 ⁵	5	0 ⁴ 0 ⁵	5	0 – 5	5	15	50	100
Old Town Business 2 ⁵	0 ³ 0 ⁷	0 ² 0 ⁵	60	0 ⁴ 0 ⁵	5	0 ⁴ 0 ⁵	5	0 – 5	5	15	50	100
Old Town Business 3 ⁵	0 ³ 0 ⁷	0 ² 0 ⁵	60	0 ⁴ 0 ⁵	5	0 ⁴ 0 ⁵	5	0 – 5	5	15	50	100

Commented [AR14]: Updated the table with the following:
 Correct Zoning Designations
 Correct Lot Size from AMC 20.36
 Correct Densities from AMC 20.36
 Existing footnote referenced rear lot setbacks and that was entered into the table.
 Changed Height for Moderate and Medium Capacity.
 Added Lot Coverage for Medium Capacity
 Updated and Added Footnotes

Zone	Minimum Lot Size Standard Subdivision (square feet)	Minimum Residential Densities (Minimum Square Feet per Dwelling Unit)	Minimum Lot Width (ft.)	Building Setback Requirements—Minimum Distance, in feet, from:							Height Limitation (ft.)	Max. Lot Coverage (%)
				Non-Arterial Street Right-of-Way ¹ Line		Arterial Street Right-of-Way ¹ Line		Rear Lot Boundary Line ²	Side Lot Boundary Line or Alley	ECA Buffer		
				Building	Freestanding Sign	Building	Freestanding Sign	Building	Building and Freestanding Sign			
General Commercial	Ø ³ Ø ⁷	N/A	70	25 – 7ldg. > 10,000 sq ft 10 – 7ldg. < 10,000 sq ft	10	25 – 7ldg. > 10,000 sq ft 10 – 7ldg. < 10,000 sq ft	10	Primary – 20 Accessory – 5	5	15	45	100
Highway Commercial	Ø ³ Ø ⁷	N/A	70	25 – 7ldg. > 10,000 sq ft 10 – 7ldg. < 10,000 sq ft	10	25 – 7ldg. > 10,000 sq ft 10 – 7ldg. < 10,000 sq ft	5	Primary – 20 Accessory – 5	5	15	50	100
<u>Commercial Corridor</u>	All Density and Dimensional Standards are Regulated by the Mixed-Use Development Regulations AMC 20.110 ⁸											
<u>Mixed-Use Overlay</u>	All Density and Dimensional Standards are Regulated by the Mixed-Use Development Regulations AMC 20.110 ⁸											
General Industrial	10,000	N/A	70	25	10	25	10	Primary – 20 Accessory – 5	5	15	50	100
Light Industrial	10,000	N/A	70	25	5	25	5	Primary – 20 Accessory – 5	5	15	50	100
Aviation Flightline ⁹	10,000	N/A	70	25	5	25	5	Primary – 20 Accessory – 5	5	15	50 ⁵	100
Medical Services	10,000	N/A	70	25	10	25	10	10	10	15	50 ⁵	100
Business Park	10,000	N/A	70	25	5	25	5	Primary – 20 Accessory – 5	5	15	50	100
Public/Semi-Public	Same as predominately surrounding zone											

Table 20.48-1 Footnotes:

¹ As used in this table, “r-o-w” or “right-of-way” means the street’s ultimate right-of-way according to its classification, not existing, actual right-of-way.

² Rear setback for principal buildings (twenty feet) and five-foot setback or accessory structures.

³ The lot size in the Residential Ultra Low Capacity (RULC) are primarily to accommodate detached single-family residential development in areas not currently served by public sewer and water facilities. Larger lots are required to accommodate a septic system and reserve area as required by the Snohomish Health District.

^{3,4} All development within the Old Town Residential district is subject to the requirements of the Old Town Residential Design Standards.

³⁵ “0” in this column means that there is no density maximum. One can build as many residential units as can fit, as long as the rest of the requirements of this code are met (e.g., parking, open space, screening, maximum lot coverage, setbacks, drainage, etc.)

⁴⁶ Maximum setbacks are required pursuant to Section 20.46.050 and the Development Design Standards for (Site Design in the Old Town Business Districts 1,2, and 3).

⁷ “0” in this column means that there is no minimum parcel size. One can subdivide into as small of lots as one wants, as long as a permissible use can fit on the lot while meeting the rest of the requirements of this code (e.g., parking, open space, screening, maximum lot coverage, setbacks, etc.)

^{5,8} All development within the Commercial Corridor and the Mixed-Use Overlay is subject to the requirements of the Mixed-Use Development Regulations.

^{5,9} Airspace restrictions may limit the maximum building height to less than fifty feet.

⁷ ~~Include a rear setback for principal buildings (twenty feet) while keeping the standard five foot setback or accessory structures.~~

20.48.110 – Density and Dimensional Diagrams

Commented [AR15]: Added a new section for Density and Dimensional Diagrams to show what is written in the code.

Figure 1: Setback Locations

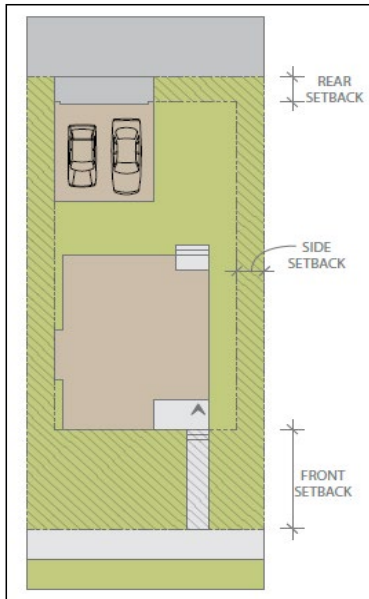

Figure 2: Fence Height and Setback Location

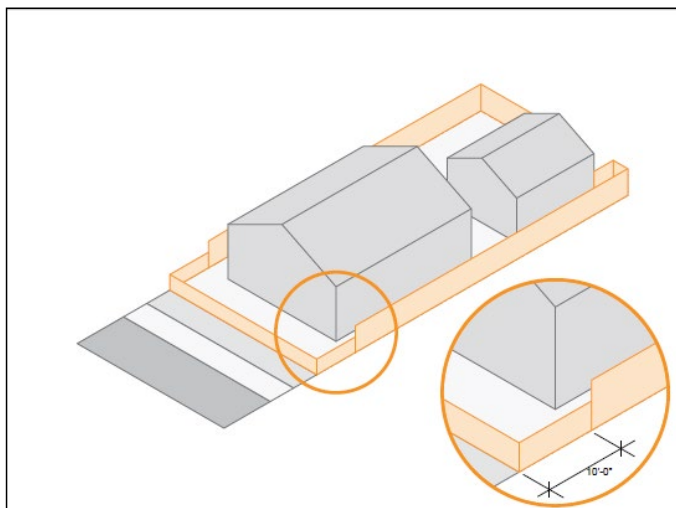

Figure 3: Site Visibility Areas (Site Triangle)

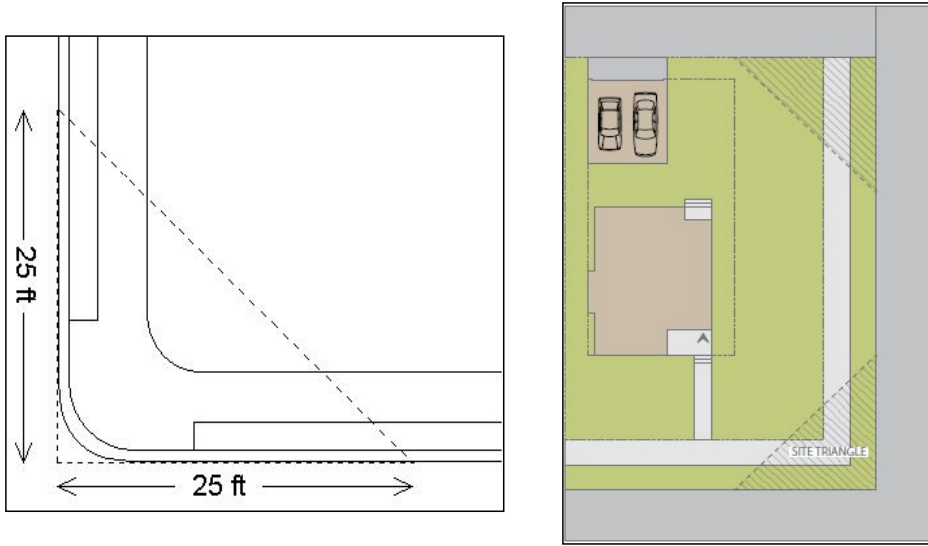

Figure 4: Driveway Locations

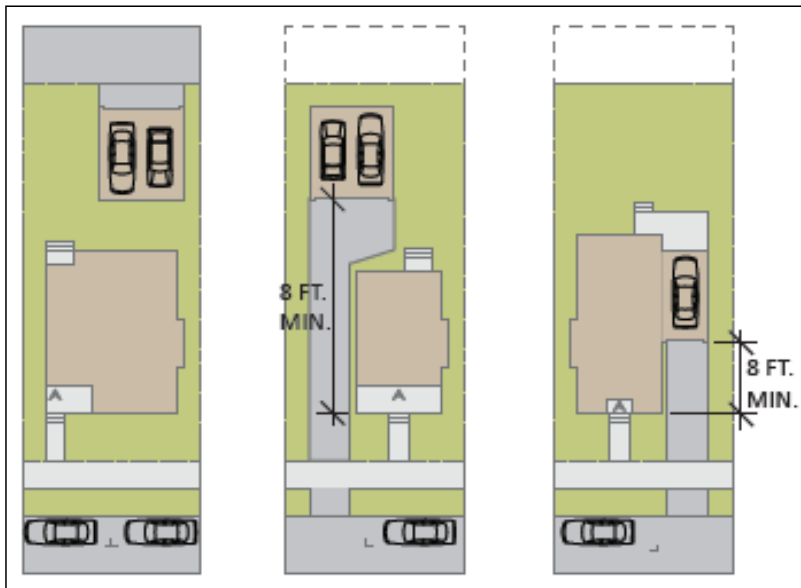

Figure 5: Accessory Building (Garage or Shed) Location on Lot

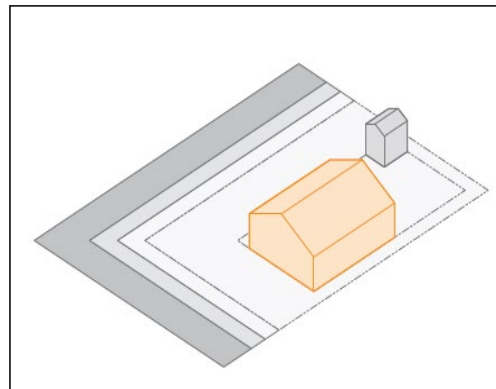
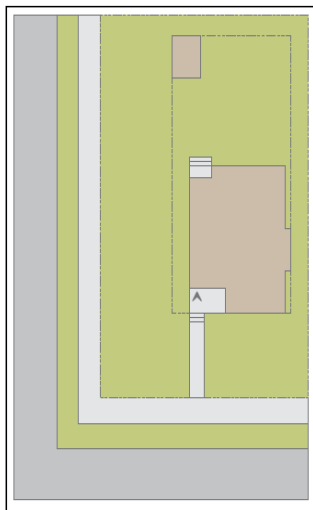
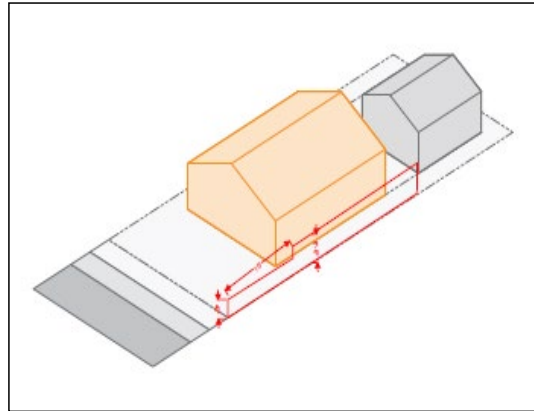
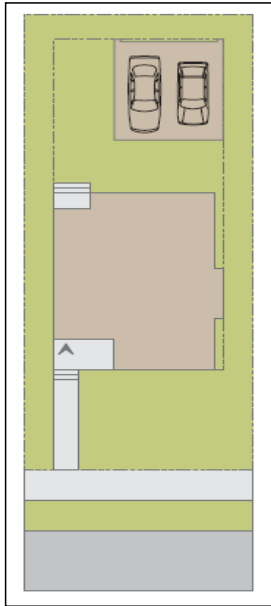
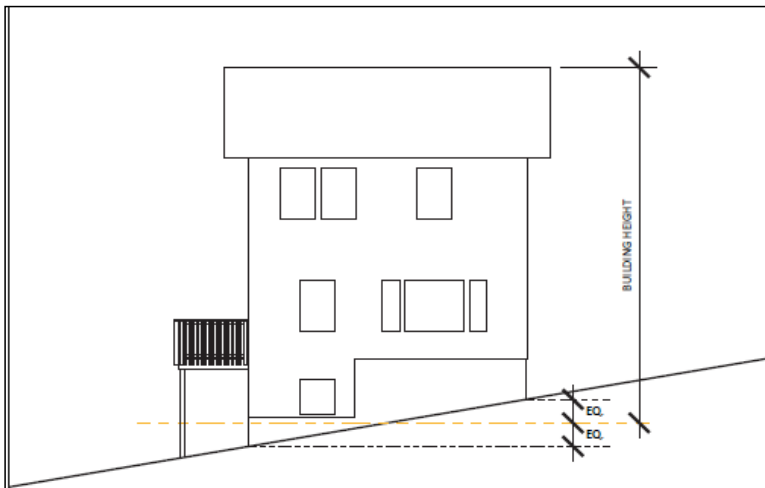
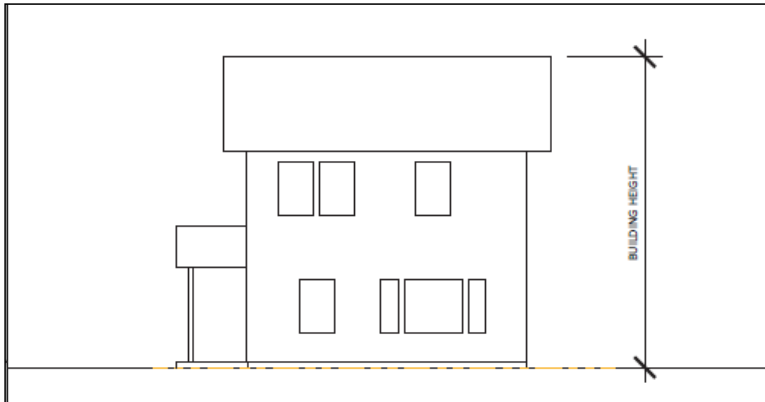

Figure 6: Building Height



20.48.120 – Lot Layout Diagrams

Commented [AR16]: Added lot layout diagrams showing how the permissible housing and building types can be located on a lot.

Figure 7: Single Family Residence

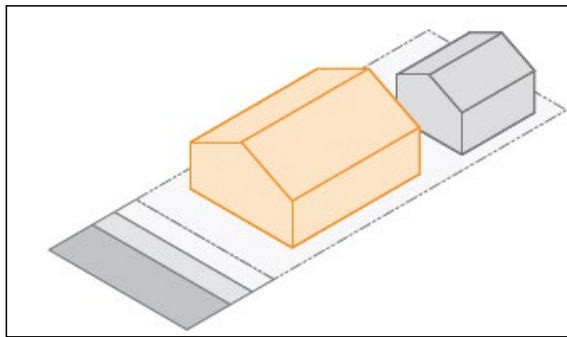
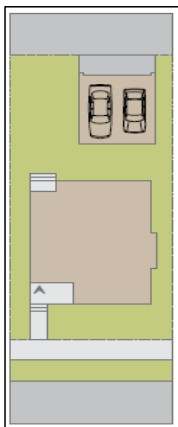
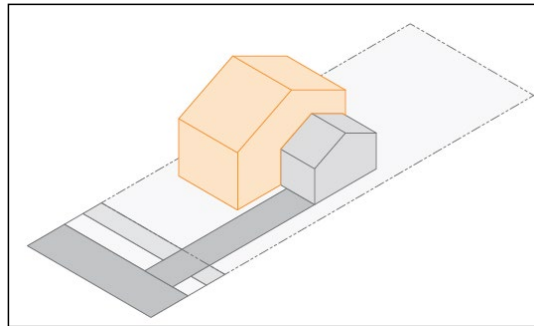
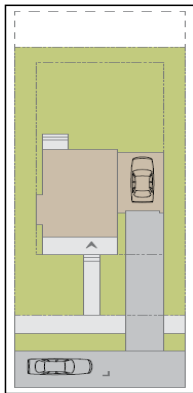
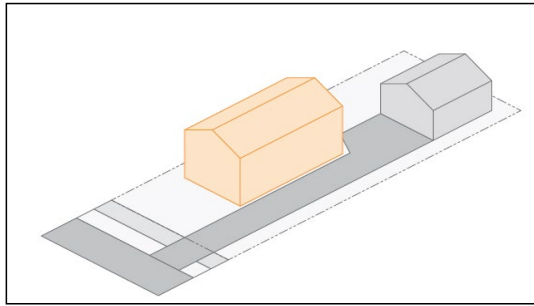
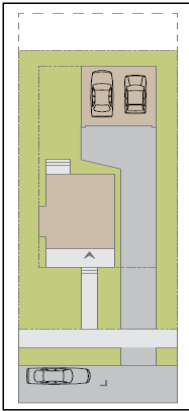

Figure 8: Duplex

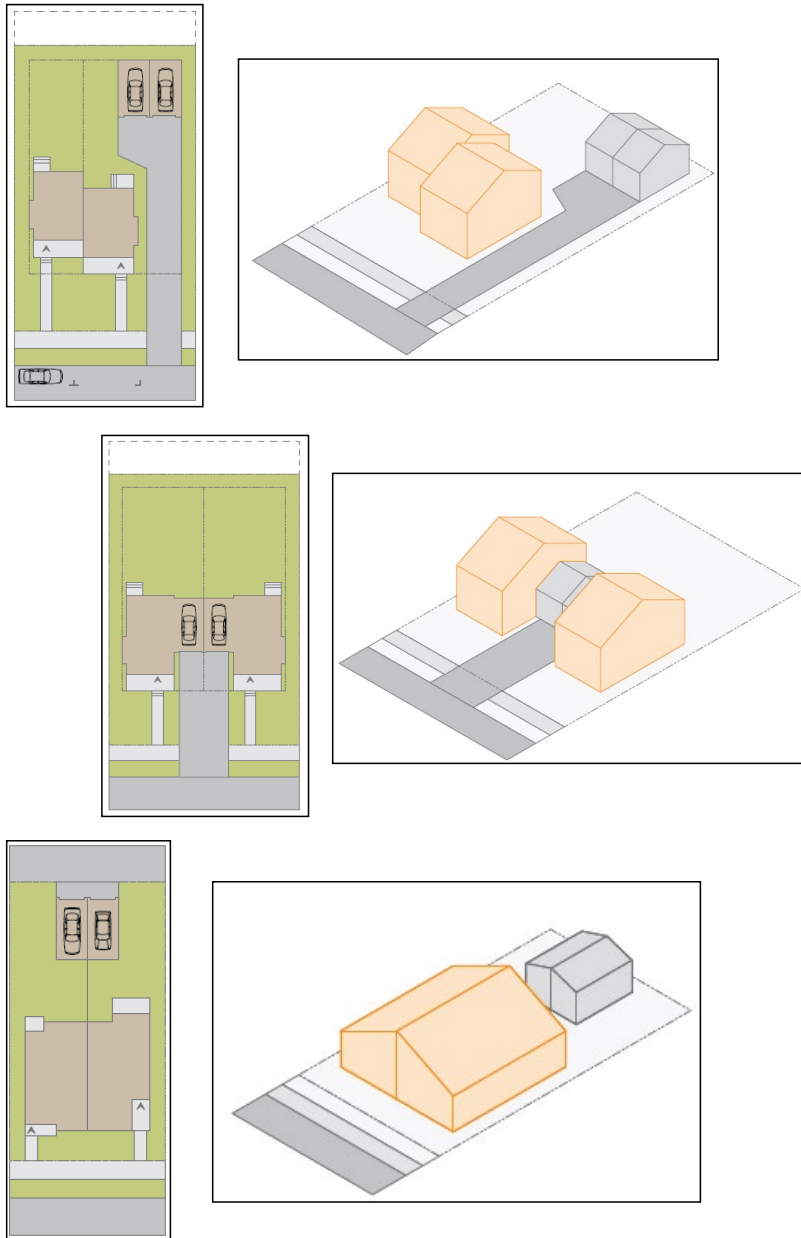

Figure 9: Triplex

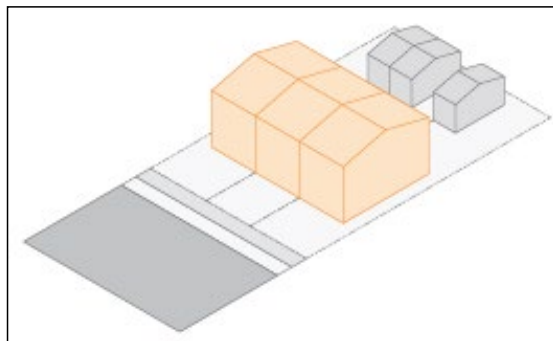
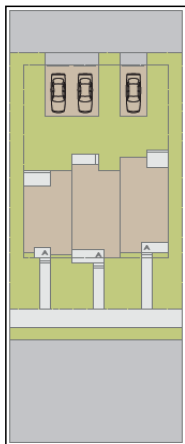
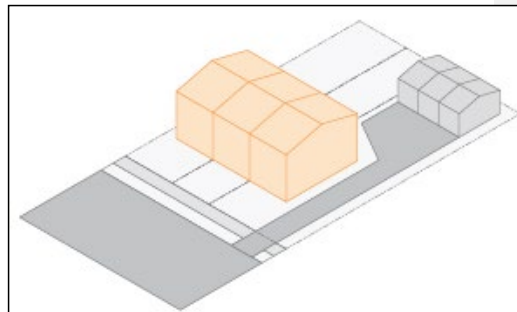
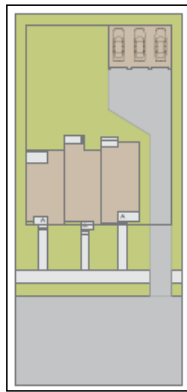
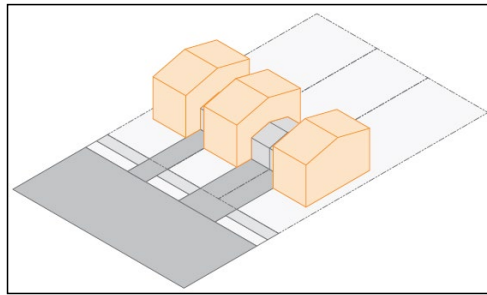
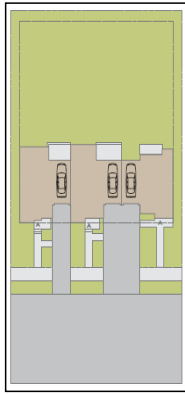

Figure 10: Townhouse

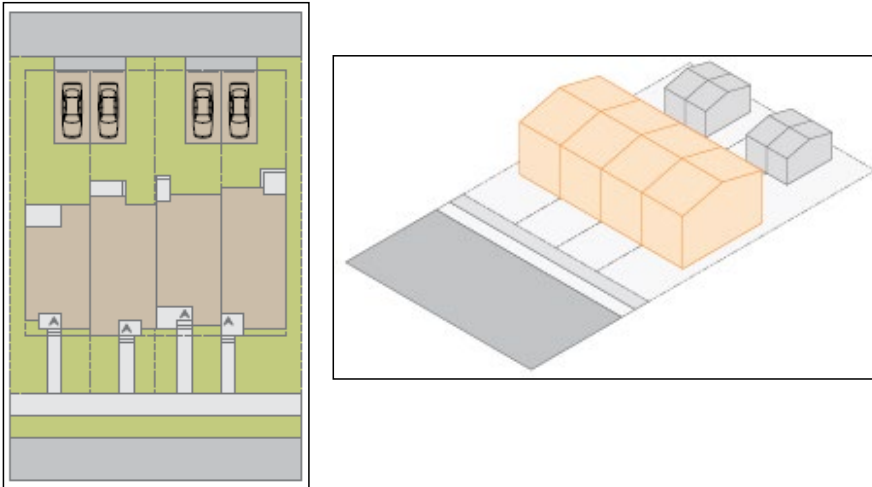

Figure 11: Cottage Housing

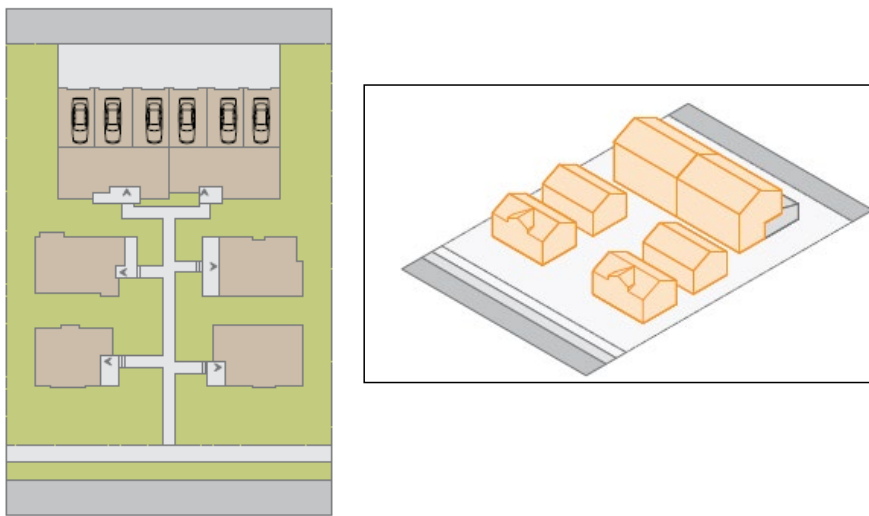

Figure 12: Multi-Family Fourplex

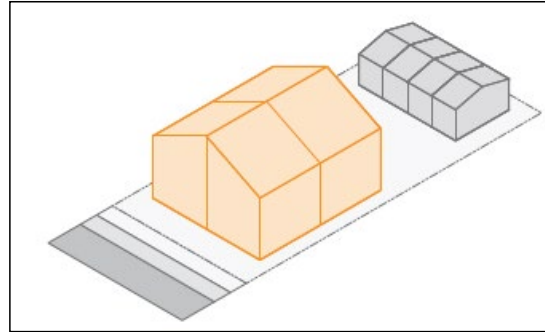
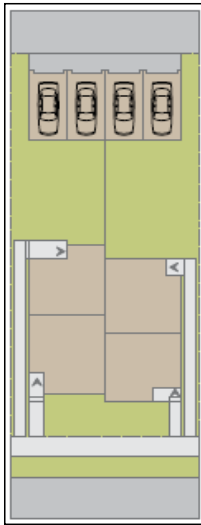

Figure 13: Multi-Family Apartment

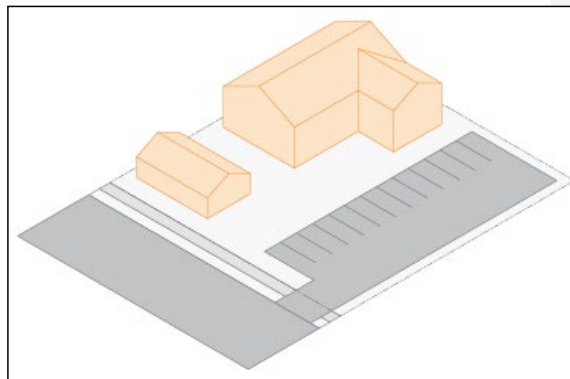
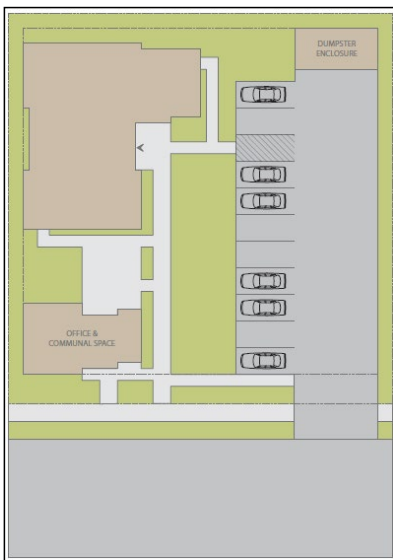

Figure 14: Rowhouse

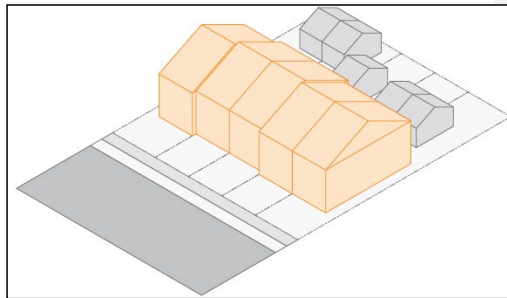
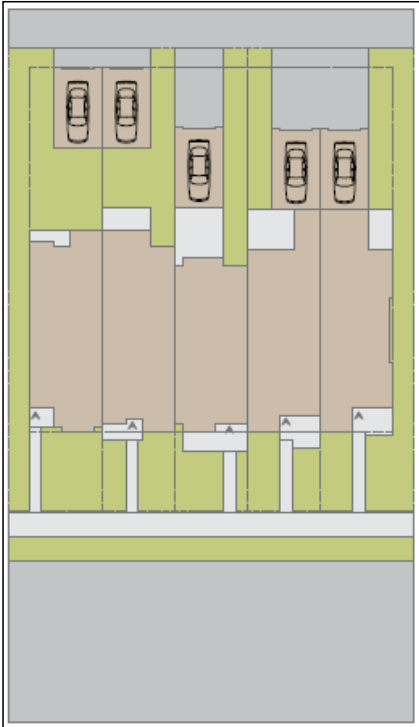
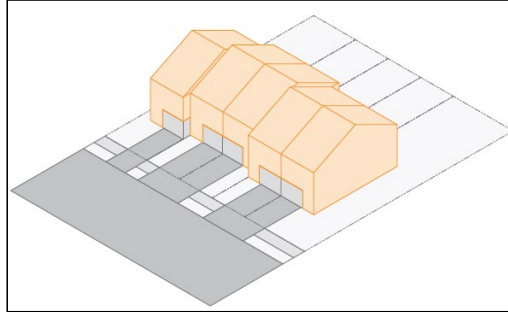
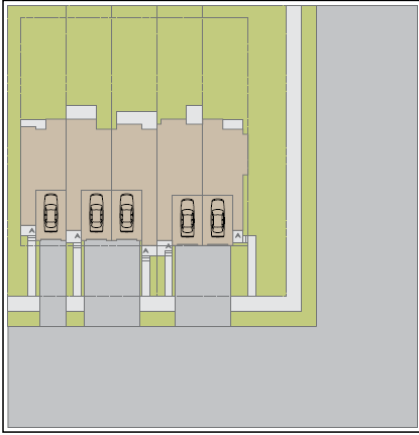

Figure 15: Multi-Family Garden Apartments

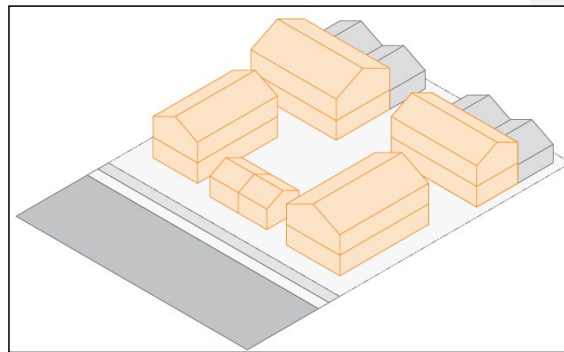
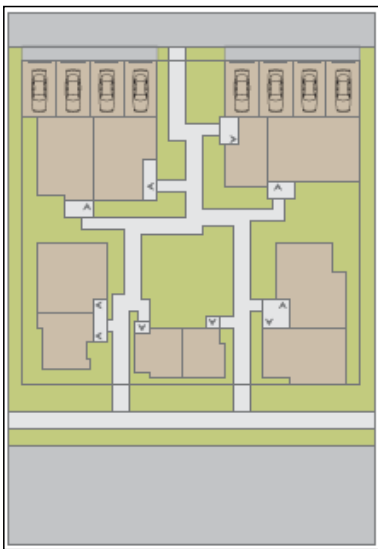
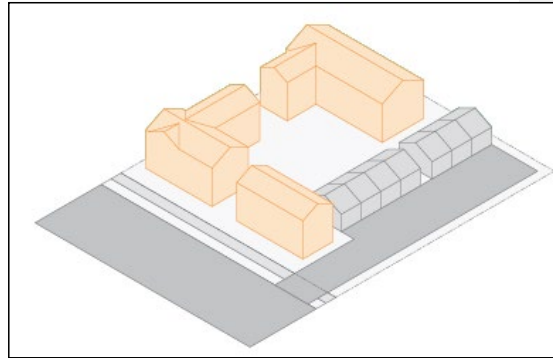
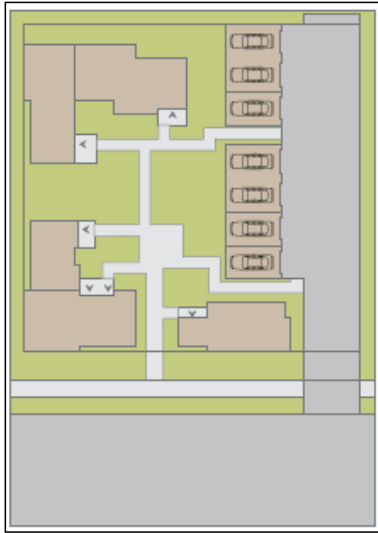
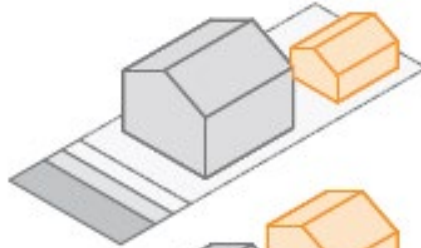
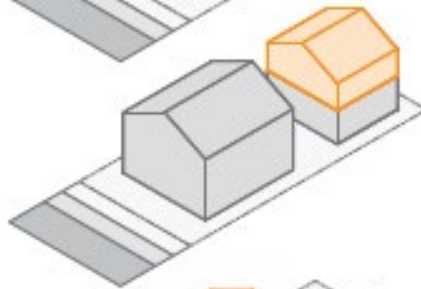

Figure 16: Accessory Dwelling Unit Locations

Detached Standalone Structure



Above an Attached Garage
Above a Detached Garage



Within the Attic of a Single-Family House

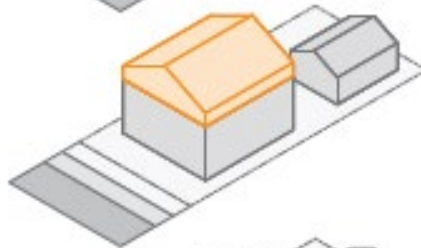

Within the Basement of a Single-Family House

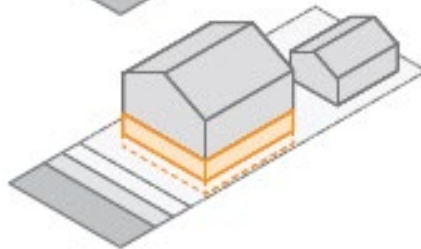

Figure 17: Commercial and Industrial Building

